

LB5000 Series*

Class 1 LED Light Bar



*Formerly "Homestead" Series

The LB5000 Series Class 1 LED Light Bar is a compact-designed, low-profile light bar that produces a powerful amber warning signal. The Homestead is our longest light bar series that includes a 53" option, but is also available in 21", 28", 34", 40" and 47" and lengths. Great for multiple applications, including tow trucks, construction, municipal, service vehicles, and work trucks. Comes equipped with 10 flash patterns that will get you noticed and keep you safe. Includes bracket mounting hardware for an easy-to-install, permanent mount to your vehicle. When you are looking for a long light bar without the bulk, the Homestead is the perfect solution for you.

FEATURES

- 6 light bars in the series
- Low profile, linear design
- Rugged Polycarbonate construction
- Lens with UV inhibitors
- 360 degree illumination provides outstanding visibility from all angles
- SAE Class 1 certified



FLASH PATTERNS

1. Single Flash*
2. Directional + Alternating + Flash
3. Single + Quint
4. Single + Triple + Quint
5. Alternating + Rapid Alternating + Flash
6. Alternating + Double Flash
7. Triple
8. Alternating + Triple Flash
9. Alternating
10. Directional

SPECIFICATIONS

INPUT VOLTAGE RANGE

9-16 VDC

CURRENT DRAW

2.5/6.5A (min/max)

LED COUNT

Varies depending on size

FLASH PATTERNS

10

OPERATING TEMPERATURE

-40° C to +65° C

DIMENSIONS

Length – varies

Width – varies

MOUNTING

Permanent (Screw)

CERTIFICATIONS

FMVSS/CMVSS 108



SAE STANDARDS J845/2139

CLASS 1

WARRANTY

3 YEAR

OPTIONS

| LENS | LED | MOUNT | CONNECTOR |
|---|---|---------|-----------|
|  CLEAR |  AMBER | BRACKET | CABLE |

* SAE J845 Class 1 Compliant

LB5000 SERIES LED LIGHT BAR INSTALLATION AND MODEL SELECTION

| PART NUMBER | SIZE "A" | MOUNT | LENS / LED | CONNECTOR |
|-------------|----------|---------|---------------|-----------|
| 100LB0008 | 21" | BRACKET | CLEAR / AMBER | CABLE |
| 100LB0009 | 28" | BRACKET | CLEAR / AMBER | CABLE |
| 100LB0010 | 34" | BRACKET | CLEAR / AMBER | CABLE |
| 100LB0011 | 40" | BRACKET | CLEAR / AMBER | CABLE |
| 100LB0012 | 47" | BRACKET | CLEAR / AMBER | CABLE |
| 100LB0037 | 53" | BRACKET | CLEAR / AMBER | CABLE |

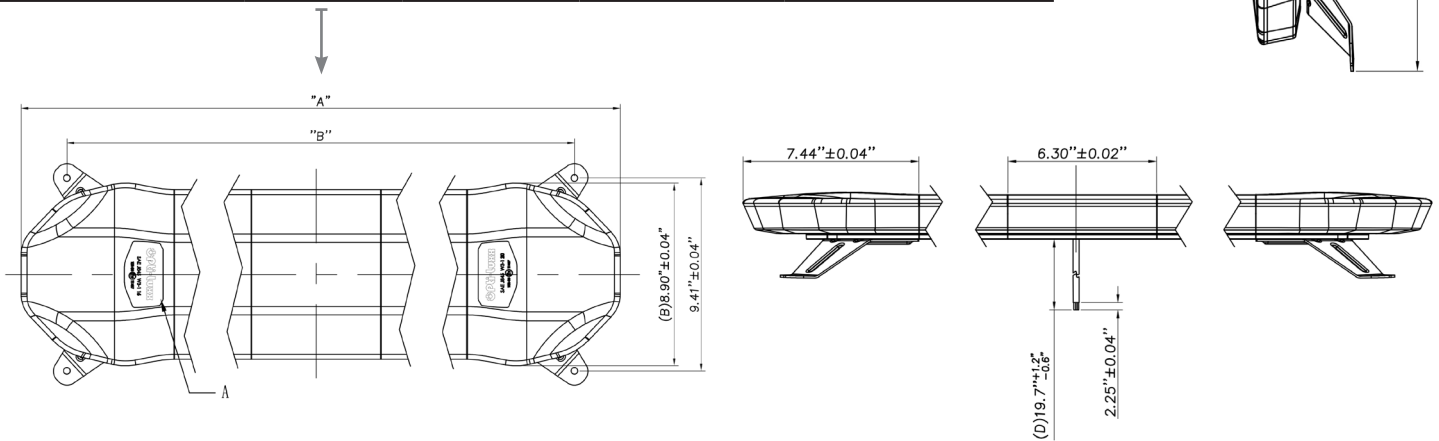
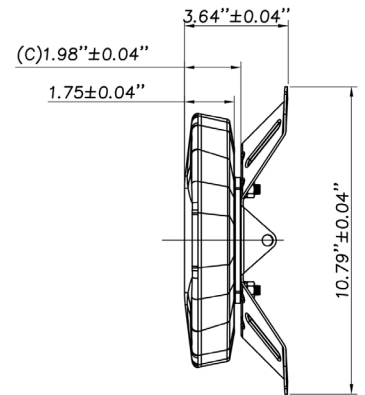

LEARN MORE

To learn more about the LB5000 Series Class 1 LED Light Bar, please visit our website at www.opti-luxx.com or call (616) 379-4142. Also, see our lighting products in action by following our YouTube channel.



Follow us on YouTube to see more Opti-Luxx products in action, including available flash patterns!



www.opti-luxx.com
(616) 379-4142