

# LB4000 Series\*

## Class 1 LED Light Bar



\*Formerly "Pocono" Series

The LB4000 Series Class 1 LED Light Bar is a compact-designed, low-profile light bar that produces a powerful amber warning signal. Measuring just 1.3" thick, our thinnest light bar series comes available in lengths from 19" to 49". Great for multiple applications, including tow trucks; construction, municipal, and service vehicles; and work trucks. Comes equipped with 10 flash patterns that will get you noticed and keep you safe. Includes bracket mounting hardware for an easy-to-install, permanent mount to your vehicle. When you are looking for a big light bar without the bulk, the Pocono is the perfect solution for you.

### FEATURES

- 5 light bars in the series
- 5 different lengths
- Rugged polycarbonate construction
- Lens with UV inhibitors
- 360 degree illumination provides outstanding visibility from all angles
- SAE Class 1 certified



### FLASH PATTERNS

1. Single Flash - Bright\*
2. Single Flash
3. Rapid Flash
4. Directional
5. Triple
6. Single + Double + Triple
7. Single + Quint
8. Directional + Triple
9. Alternating
10. Rapid Alternating

### SPECIFICATIONS

#### INPUT VOLTAGE RANGE

10-30 VDC

#### CURRENT DRAW

2.4/3.9A (min/max)

#### LED COUNT

Varies depending on size

#### FLASH PATTERNS

10

#### OPERATING TEMPERATURE

-40 C to +65 C

#### DIMENSIONS

Length - 19"-49"

Width - 7.86"

#### MOUNTING

Screw

#### CERTIFICATIONS



SAE J845/2139 CLASS 1

FMVSS/CMVSS 108

#### WARRANTY

3 YEAR

### OPTIONS

LENS	LED	MOUNT	CONNECTOR
 CLEAR	 AMBER	BRACKET	CABLE

\* SAE J845 Class 1 Compliant

**LB4000 SERIES CLASS 1 LIGHT BAR INSTALLATION AND MODEL SELECTION**

PART NUMBER	SIZE "A"	MOUNT	LENS / LED	CONNECTOR
100LB0018	19"	BRACKET	CLEAR / AMBER	CABLE
100LB0019	25"	BRACKET	CLEAR / AMBER	CABLE
100LB0020	31"	BRACKET	CLEAR / AMBER	CABLE
100LB0021	37"	BRACKET	CLEAR / AMBER	CABLE
100LB0022	49"	BRACKET	CLEAR / AMBER	CABLE

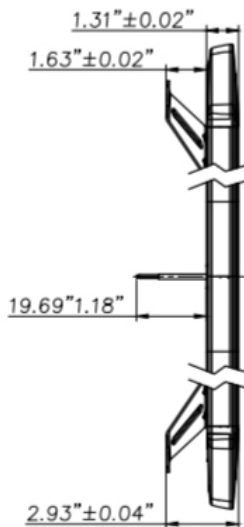
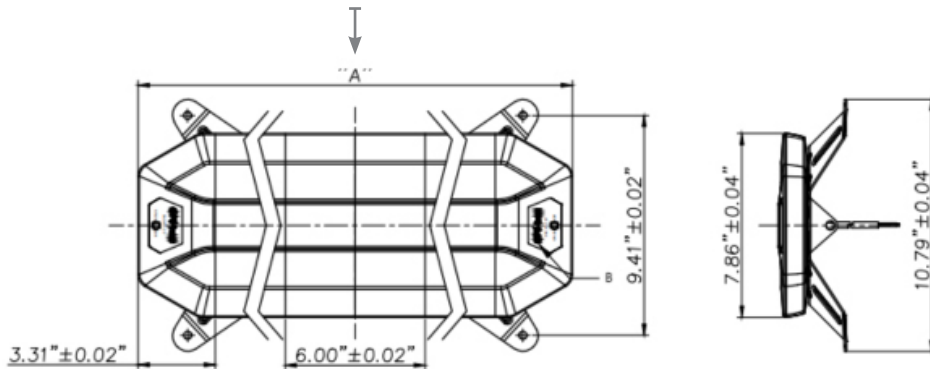

**LEARN MORE**

To learn more about the LB4000 Series Class 1 LED Light Bar, please visit our website at [www.opti-luxx.com](http://www.opti-luxx.com) or call (616) 379-4142. Also, see our lighting products in action by following our YouTube channel.



*Follow us on YouTube to see more Opti-Luxx products in action, including available flash patterns!*



[www.opti-luxx.com](http://www.opti-luxx.com)  
(616) 379-4142