

# FONTANA

## Class 1 LED Light Bar



The Fontana Class 1 LED Light Bar is a sturdy, high profile light bar that produces a powerful amber warning signal. Available in multiple sizes from 18" to 45", the Fontana provides your commercial vehicle with a superior safety lighting product. Great for multiple applications including tow trucks, construction, municipal, service vehicles, and work trucks. Comes equipped with 10 flash patterns that will get you noticed and keep you safe. Includes bracket mounting hardware for an easy to install, permanent mount to your vehicle. A big light bar without the big price tag, the Fontana is the perfect fit for the job.

### FEATURES

- 4 light bars in the series
- Multiple sizes – 18", 27", 36", 45"
- Rugged polycarbonate construction
- Lens with UV inhibitors
- 360 degree illumination provides outstanding visibility from all angles
- SAE Class 1 certified



### FLASH PATTERNS

1. Single Flash\*
2. Directional + Alternating + Double Flash
3. Single + Quad
4. Single + Triple + Quint
5. Alternating + Rapid Alternating + Flash
6. Alternating + Flash + Rapid Flash
7. Quad
8. Alternating + Double Flash
9. Rapid Alternating
10. Directional

### SPECIFICATIONS

#### INPUT VOLTAGE RANGE

10-30 VDC

#### CURRENT DRAW

2.5/3.7A (min/max)

#### LED COUNT

Varies depending on size

#### FLASH PATTERNS

20

#### OPERATING TEMPERATURE

-40° C to +65° C

#### DIMENSIONS

Length – 18" - 45"

Width – 12.02"

#### MOUNTING

Permanent (Screw)

#### CERTIFICATIONS



SAE J845/2139 CLASS 1

FMVSS/CMVSS 108

#### WARRANTY

3 YEAR

### OPTIONS

LENS	LED	MOUNT	CONNECTOR
 CLEAR	 AMBER	BRACKET	CABLE

\* SAE J845 Class 1 Compliant

FONTANA LED LIGHT BAR INSTALLATION AND MODEL SELECTION

PART NUMBER	SIZE "A"	MOUNT	LENS / LED	CONNECTOR
100LB0027	18"	BRACKET	CLEAR / AMBER	CABLE®
100LB0028	27"	BRACKET	CLEAR / AMBER	CABLE
100LB0029	36"	BRACKET	CLEAR / AMBER	CABLE
100LB0030	45"	BRACKET	CLEAR / AMBER	CABLE

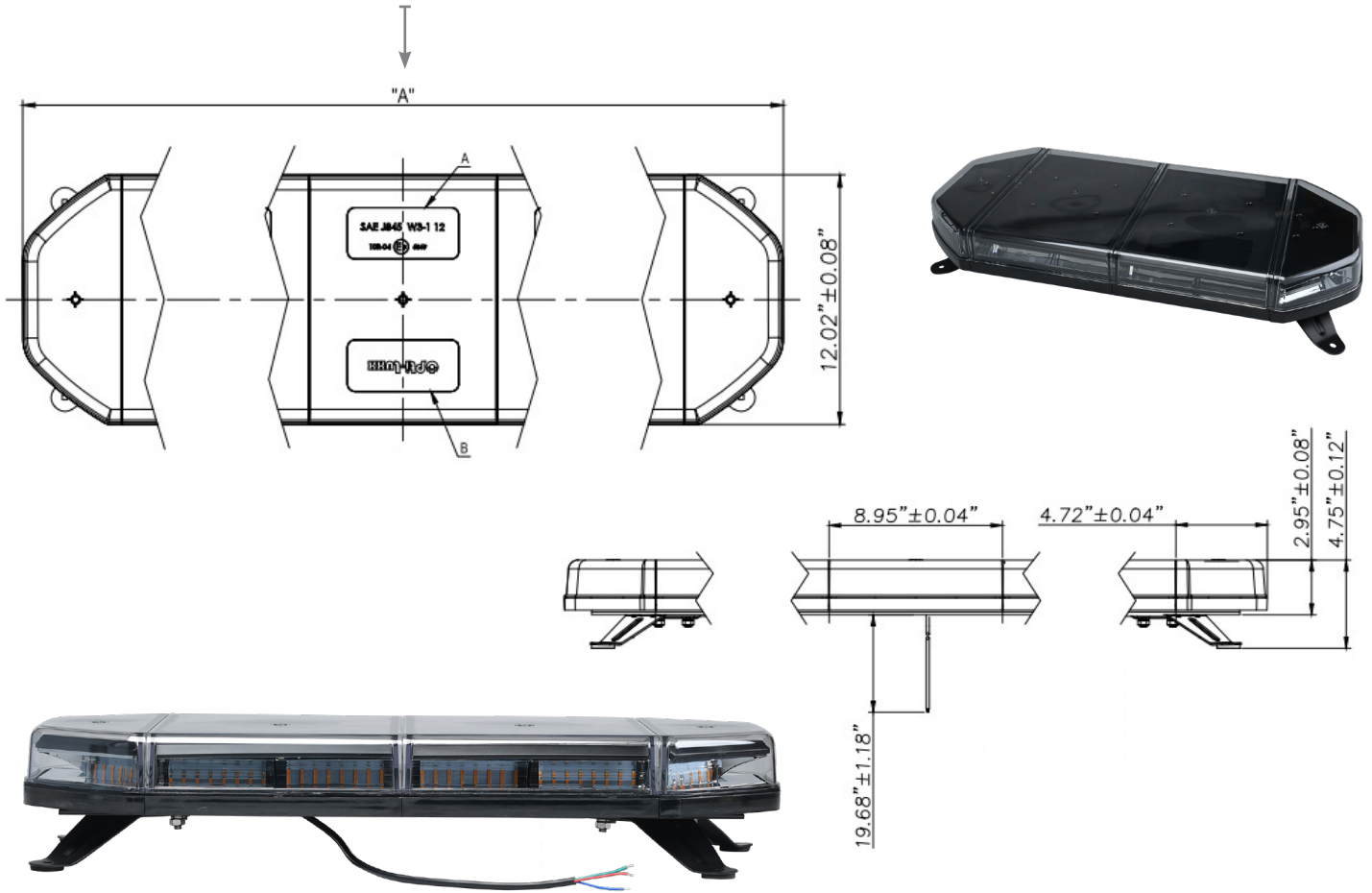

LEARN MORE

To learn more about the Fontana Class 1 LED Light Bar, please visit our website at [www.opti-luxx.com](http://www.opti-luxx.com) or call (616) 379-4142. Also, see our lighting products in action by following our YouTube channel.



Follow us on YouTube to see more Opti-Luxx products in action, including available flash patterns!



[www.opti-luxx.com](http://www.opti-luxx.com)  
(616) 379-4142